

**FOR SALE**

316 HOWARD AVENUE  
 DES PLAINES, IL 60018

CONTACT US TODAY:

**Eric Wagener**

847-706-7155

ewagener@owenwagener.com

Owen Wagener & Co.

37 Sherwood Terrace, Suite 122

Lake Bluff, IL 60044

www.owenwagener.com



**OFFICE/WAREHOUSE**

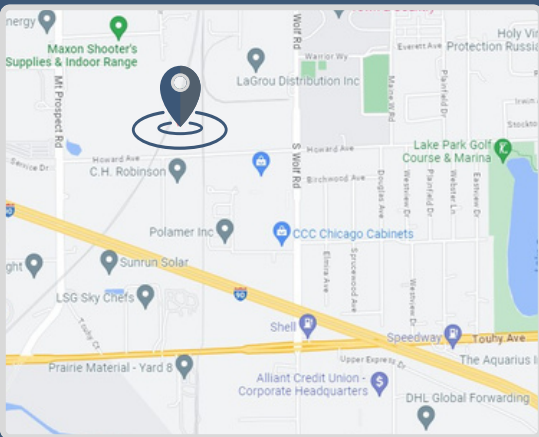

**SPECS:**

- 3 PRIVATE OFFICES
- EXCELLENT WINDOW LINE - CORNER UNIT
- UPSCALE PROFESSIONAL COMPLEX
- 100% AIR-CONDITIONED
- EXTERIOR LOADING DOCK
- MINUTES TO O'HARE AIRPORT & I-90, 294

<b>Total Building Size:</b>	<b>1,800 SF</b>
<b>Description:</b>	<b>Office Warehouse Condo</b>
<b>Year Built:</b>	<b>1986</b>
<b>Land Area:</b>	<b>30,800 SF</b>
<b>Parking:</b>	<b>2.6:1,000 SF</b>
<b>Power:</b>	<b>100 Amps/3-Phase</b>
<b>Loading:</b>	<b>Common Exterior Loading Dock</b>
<b>HVAC:</b>	<b>Gas Forced Air &amp; 100% A/C</b>
<b>Zoning:</b>	<b>Light Industrial</b>
<b>Taxes:</b>	<b>2022 Estimated Taxes \$6.75/SF</b>
<b>Asking Price:</b>	<b>\$180,000.00</b>

All information herein is from sources reliable but not guaranteed accurate. Subject to errors, omissions, and to changes of price and terms, prior sale or lease, all without notice.

# 316 HOWARD AVENUE DES PLAINES, IL 60018

1,800 SF

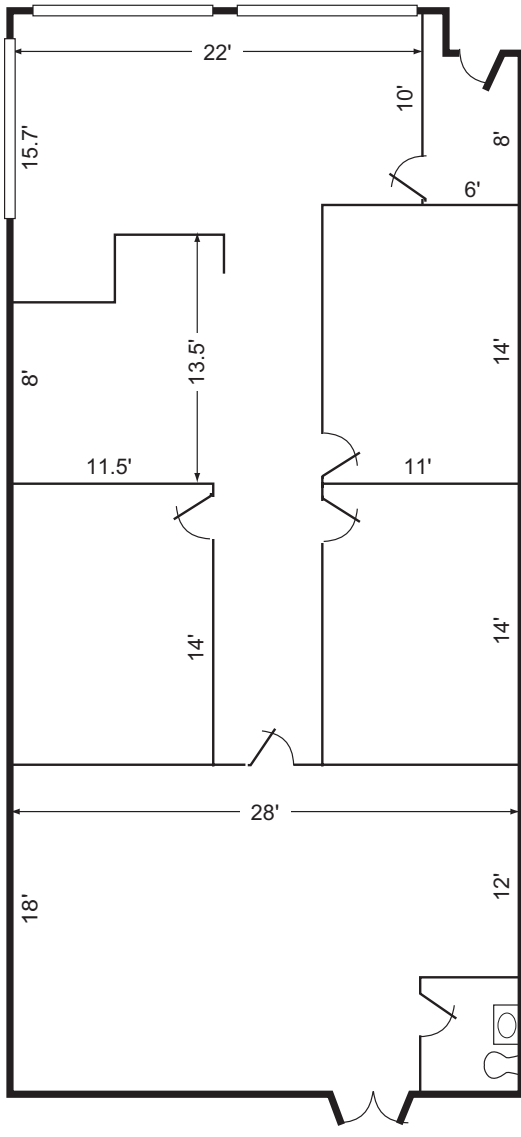

Double Doors

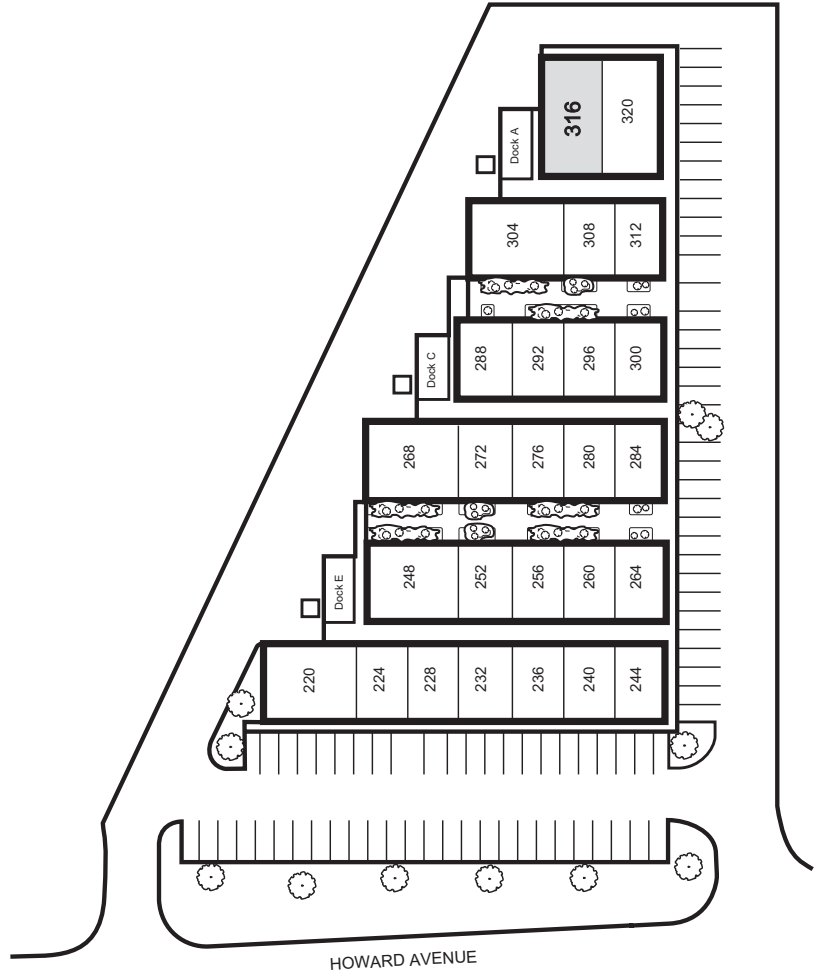

YOUR CHICAGOLAND COMMERCIAL  
REAL ESTATE EXPERT, SINCE 1964.

[WWW.OWENWAGENER.COM](http://WWW.OWENWAGENER.COM)